

# Source Four PAR

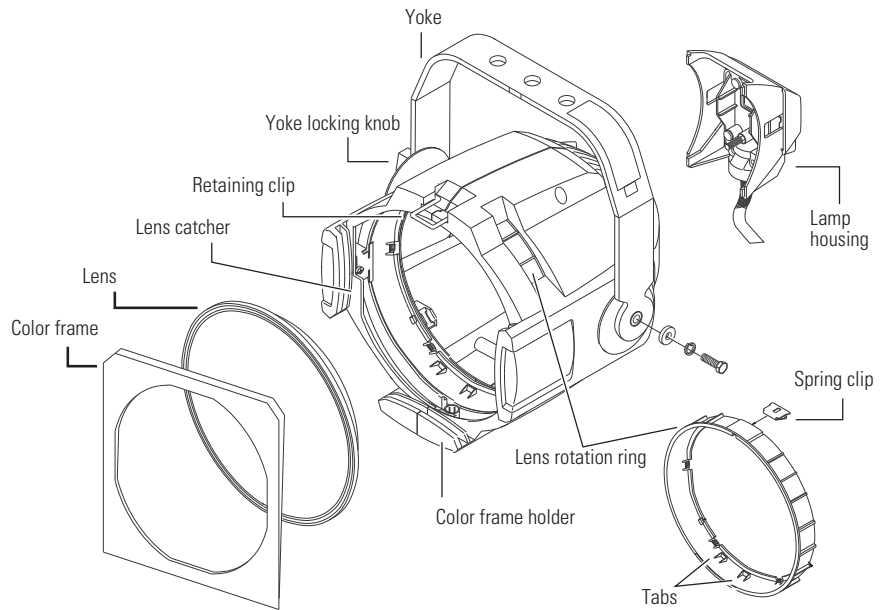

## Source Four PAR

Please note the following safety warnings before use:

- **Do not** mount the Source Four PAR on or near combustible surfaces.
- **Do not** operate the Source Four PAR without a lens installed.
- Always hang the Source Four PAR with the color frame retaining clip in the locked position.

## Accessories

Color frame 7.5 in. sq./6.7 in. inside diameter)	407CF
Safety cable (31 in.)	400SC
C-clamp	400CC
Very Narrow Spot lens	400-VNSP
Narrow Spot lens	400-NSP
Medium Flood lens	400-MFL
Wide Flood lens	400-WFL
Set of four Source Four PAR lenses (VNSP, NSP, MFL, WFL)	400LS4



## HPL lamps

Use the HPL lamp only in Source Four and Source Four PAR fixtures manufactured and sold by Electronic Theatre Controls, Inc. **Do not** use lamps other than the HPL in Source Four PAR fixtures.

	Lamp code	Watts	Volts	Color temp	Ave rated life
American	HPL 375/115	375	115	3,250°K	300 hour
	HPL 375/115X	375	115	3,050°K	1,000 hour
	HPL 550/77	550	77	3,250°K	300 hour
	HPL 550/77X	550	77	3,050°K	2,000 hour
	HPL 575/115	575	115	3,250°K	300 hour
	HPL 575/115X	575	115	3,050°K	2,000 hour
	HPL 575/120	575	120	3,250°K	300 hour
Euro.	HPL 575/230	575	230	3,200°K	400 hour
	HPL 575/240	575	240	3,200°K	400 hour

## Installing the HPL lamp

Always replace the lamp if it becomes damaged or deformed.

Verify that the HPL lamp you use is suitable for the voltage at your facility. 115, 120, 230, and 240 volt HPL lamps are available.

**Caution!** Operating lamps above their rated voltage reduces lamp life and can cause premature lamp failure.

1. Disconnect the unit from power before installing the lamp.

**WARNING!** Let lamp cool before changing.

2. Loosen the knurled bolt on the back of the lamp housing and pull the housing straight out from the back of the fixture.
3. Remove the HPL lamp from its box, holding it by the base.

**Note:** To avoid premature lamp failure, do not touch the lamp glass with your fingers. If you touch the lamp during installation, clean it carefully with rubbing alcohol and a clean, lint-free cloth before operation.

4. Line up the flat sides of the lamp base with the brackets on either side of the socket (**Figure 1**).
5. Push down on the lamp base until the lamp is firmly seated. Make sure that the lamp is fully seated, with the bottom of the lamp heat sink flush to the lamp housing casting.

**Caution!** Improperly installed lamps cause premature lamp failure and socket problems.

6. To reinstall the lamp housing, center it on the reflector and the bolt hole, then tighten the knurled bolt to secure the lamp housing in place.

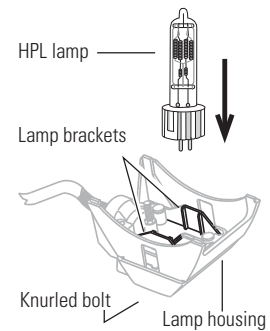
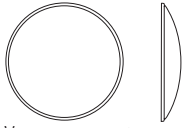

**Figure 1**

## Lens identification

Lenses for the Source Four PAR come in four versions. The type or beam spread can be identified by the lens texture.

### VNSP



Very narrow spot  
Clear glass  
15° Round beam shape

### NSP



Narrow spot  
Stipple glass (slight diffuse texture)  
19° Round beam shape

### MFL

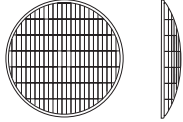

Medium flood  
Fewer facets, sized 6 x 22mm  
21° x 34° Oblong beam shape

### WFL

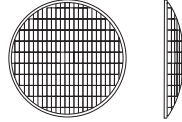

Wide flood  
Many facets, sized 6 x 12mm  
30° x 51° Oblong beam shape

## Changing Source Four PAR lenses

Change lenses if they become cracked or badly scratched.

**Caution!** Never operate the Source Four PAR without a lens in place.

### Removing a lens

**WARNING!** Unplug the fixture before attempting to remove or install a lens.

1. Source Four PAR lenses get hot while the unit is in operation. Let the fixture cool before handling the lens.
2. Place the fixture on a flat, stable work surface. **Do not** install or remove lenses with the unit hanging.
3. Position the lens rotation ring with the spring clip at the top of the unit, directly below the retaining clip.
4. Tilt the front of the fixture down at least 45 degrees.
5. Press the spring clip with your finger to release the lens (**Figure 2**).
6. Allow the lens to drop forward from under the clip.
7. When the lens drops, remove your finger, allowing the lens to slide forward until it rests on the lens catchers (**Figure 3**).
8. Carefully remove the lens from the fixture.

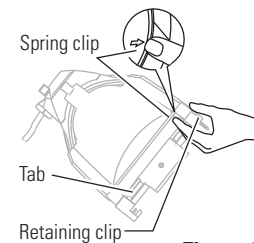

Figure 2

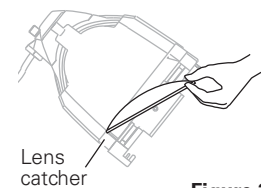

Figure 3

### Installing a lens

1. Position the fixture with the front of the unit (the lens side) facing you, and tilted slightly (**Figure 2**).
2. Position the lens rotation ring with the spring clip at the top of the fixture, directly below the retaining clip.
3. Hold the lens by the edge, and position it so the convex side faces the back of the fixture (**Figure 4**).

**Note:** Installing the lens with the convex side out will not impair the optics, but it will make removing the lens difficult.

4. From the top of the fixture, slide the lens behind the lens catchers and position its base behind the tabs on the bottom of the lens rotation ring.
5. Gently push the top of the lens inward until it snaps behind the spring clip.

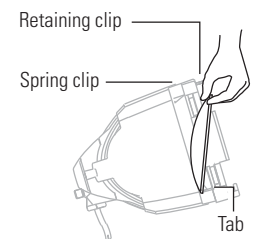

Figure 4

## Color frame retaining clip

The color frame holder is equipped with a spring-loaded retaining clip that prevents color frames and accessories from falling out.

---

**WARNING!** *Hang the Source Four PAR with the color frame retaining clip in the locked position.*

---

1. Release the retaining clip by pushing it sideways. The retaining clip opens.
2. Insert the color frame.
3. Press the retaining clip down until it locks.

**Note:** *Use only color frames or top hats with 6.7-inch inside diameter.*

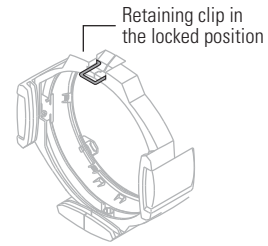

**Figure 5**

## Cleaning the reflector

ETC offers the following recommendations when cleaning and inspecting lenses and reflectors:

**Do not** use glass and window cleaners on the reflector. Chemicals in these cleaners will harm the reflective coating.

**Do not** use paper towels or harsh materials to wipe the reflector. These materials can scratch the surface of the reflector.

---

**WARNING!** *Unplug the fixture before attempting to clean reflector.*

---

1. Remove the lens so you can access the reflector from the front of the fixture. See **Removing a lens** on page 3.
2. Remove dust with a blast of oil free air, or wipe with a clean, soft, lint-free cotton cloth. If this is sufficient to remove dust, go to step 5. Otherwise, continue to step 3.
3. Dampen a clean, soft, lint-free cotton cloth with a mild, soapy water solution and gently wipe the reflector.
4. Remove any soapy water residue with a clean, soft, lint-free cotton cloth dampened with water.
5. Reinstall a lens before using the fixture.



### Electronic Theatre Controls

**North America** 3030 Laura Lane • Middleton, Wisconsin 53562 • USA • Tel: (+1) 608 831 4116 • Fax: (+1) 608 836 1736

**Europe** 5 Victoria Industrial Estate • Victoria Road • London W3 6UU • Tel: (+44) 181 896 1000 • Fax: (+44) 181 896 2000

**Asia** Room 605-606 • Tower III • Enterprise Square • 9 Sheung Yuet Road • Kowloon Bay • Hong Kong • Tel: (+852) 2799 1220 • Fax: (+852) 2799 9325

**World Wide Web:** <http://www.etccconnect.com> • **Email:** [mail@etccconnect.com](mailto:mail@etccconnect.com)

Specifications subject to change. Source Four PAR is protected by US patent numbers 5,268,613.

US and International Patents Pending. 7061M1001.

Copyright 1998

Revised 11/98.