



TOCCATA™

Condenser profile spotlights

2000/2500W

Features

Toccata brings high levels of performance and flexibility to opera houses, large theatres and other auditoria where the crisper projection qualities of condenser optics is preferred.

- ❑ Highly efficient condenser collection system designed around 2500W CP91 lamp for increased performance.
- ❑ High efficiency lens systems giving two variable beam angle profile spots covering angles from 10° to 38°
- ❑ Three plane rotating gate with four shutter blades for unsurpassed beam shaping control
- ❑ Toccata incorporates articulated yoke for over stage bridge mounting at steep angles
- ❑ Toccata features super quiet fan assisted lamphouse cooling with microswitch isolated lamp change system for improved safety
- ❑ Durable, lightweight and compact construction of pressure die cast and formed sheet aluminium covers
- ❑ Anti-reflection coated lenses for optimum performance

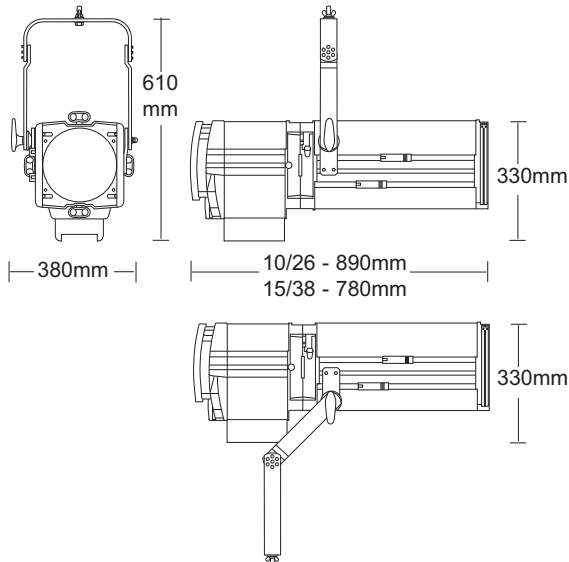

Weights and dimensions

	Toccata 10/26	Toccata 15/38
Weight	20.5kg	19.8kg
Packed Weight	29kg	25.5kg
Packed Volume	0.26m ³	0.24m ³



Performance guide

Typical performance based on laboratory readings using CP92 2000W lamp

Toccata 10/26: Narrow (10°)

Distance (m)	12	15	20	25	30
Beam Ø (m)	2.1	2.6	3.5	4.4	5.2
Illum (lux)	-	2710	1525	980	680

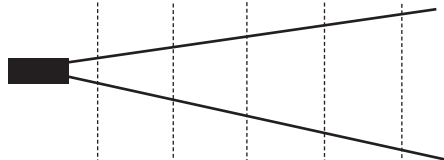

Toccata 15/38: Narrow (15°)

Distance (m)	12	15	20	25	30
Beam Ø (m)	3.2	3.9	5.3	6.6	7.9
Illum (lux)	2430	1555	875	560	390

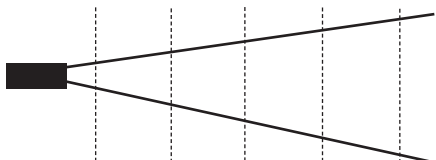

Toccata 10/26: Wide (26°)

Distance (m)	12	15	20	25	30
Beam Ø (m)	5.5	6.9	9.2	11.5	13.9
Illum (lux)	800	510	290	185	130

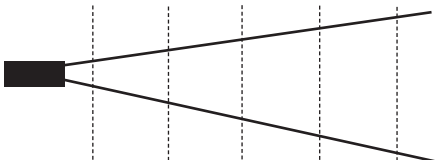

Toccata 15/38: Wide (38°)

Distance (m)	12	15	20	25	30
Beam Ø (m)	8.3	10.4	13.8	17.3	20.7
Illum (lux)	470	300	170	110	75

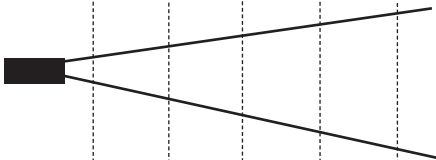

To calculate lux levels at any throw distance divide the following factors by the distance squared:

	Toccata 10/26	Toccata 15/38
Narrow	609975	349875
Wide	114975	67950

To calculate beam diameters at any throw distance multiply the throw in metres by the following factors:

	Toccata 10/26	Toccata 15/38
Narrow	0.175	0.26
Wide	0.46	0.69

Ordering information

Toccata 230V models are fitted with colour frame, 2000W CP92 lamp, integral 24-leaf iris, bridge mounting fork as well as a compact fork. 240V models come with colour frame, 2500W CP91 lamp and compact fork.

Cat No Description

12154	Toccata 10/26, 240V CP91 2500W lamp, 15A plug
12153	Toccata 10/26, integral iris, 230V CP92 2000W lamp, Schuko plug
12164	Toccata 15/38, 240V CP91 2500W lamp, 15A plug
12163	Toccata 15/38, integral iris, 230V CP92 2000W lamp, Schuko plug

Optional accessories and lamps

18202	Gobo holder for 'A' size gobos
18209	Iris, 24 leaf
18208	Compact fork option
18207	Bridge fork option
82011	Hook clamp, heavy duty
82001	Safety cable, heavy duty
18050	Shutter gate upgrade kit
18203	Additional colour frame, metal
43914	CP91 Lamp 2500W, 3200K, 400Hr - 240V
43913	CP91 Lamp 2500W, 3200K, 400Hr - 230V
43924	CP92 Lamp 2000W, 3200K, 400Hr - 240V
43923	CP92 Lamp 2000W, 3200K, 400Hr - 230V

Operational data

Lamp Access

Retractable lamp holder assembly with automatic double pole microswitch isolation

Focus Adjustment

By locking screw handles on side of lens tubes with focus setting indication provided

Suspension

Supplied with articulated fork for over stage bridge mounting. 230V models supplied with additional compact fork

Accessories

Colour runners take DIN standard 245 x 245 mm colour frames

Gobo size: A

A built in 24 leaf iris is installed in 230V models but is an optional accessory with 240V models

Mechanical/electrical data

Construction

Pressure die cast front and rear panels with extruded aluminium tie bars and formed aluminium cover panels all finished in two tone grey and black epoxy powder coating.

Lamphouse/Cooling

Light collection system uses hemi-spherical reflector and double lens condenser. Aspherical condenser lens is cooled by convection but assisted by quiet running axial fan

Gate/Lenstube

Pressure die cast gate assembly is fully rotatable and incorporates three planes housing four fully retained beam shaping shutters and runners for gobo holder.

Lenses

Heat resistant crown glass lenses with anti-reflective coatings in die cast carriers sliding on bearing rods.

Lampholder

G22 to take lamps of 90 mm LCL and maximum of 2500W

Supply Voltage

230V +/- 10% 50/60 Hz

The Company reserves the right to make any variation in design or construction to the equipment described. © Strand Lighting Ltd 1998. Strand™ and Strand Lighting™ are trade marks of Strand Lighting Limited and Strand Lighting Inc.